

# Transistor Flasher Kit

MitchElectronics 2018

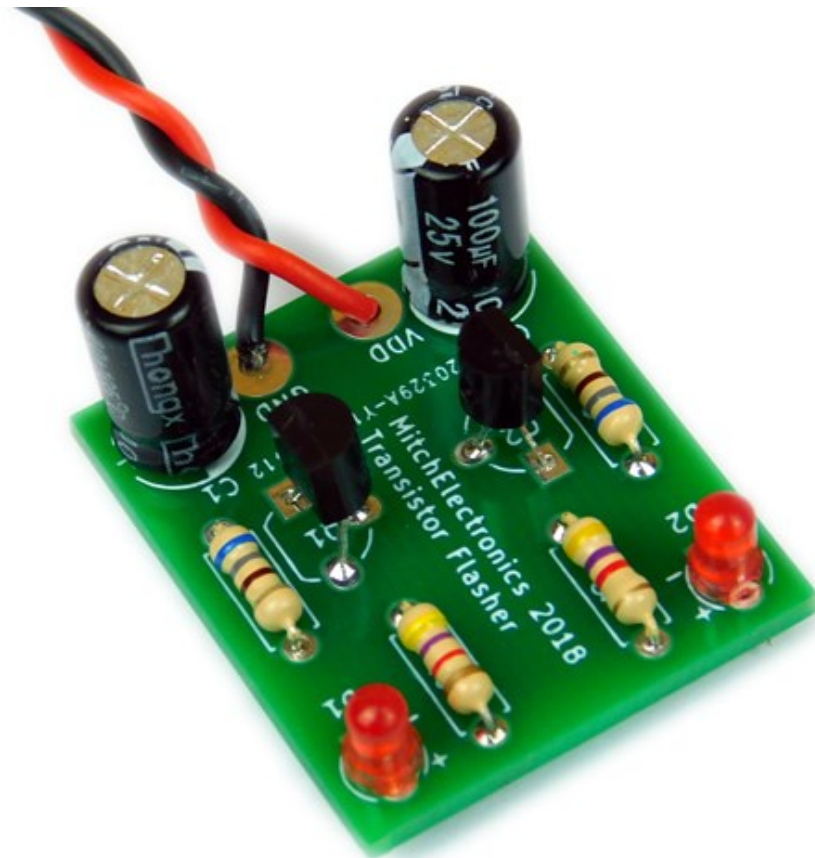

# CONTENTS

---

Introduction ...	3
Schematic ...	4
How It Works ...	5
Materials ...	6
Construction ...	7
Important Information ...	8

# INTRODUCTION

In electronics it is sometimes required to have a signal that consistently creates a continuous pulse (like the second hand on a clock which ticks every second). Examples of where this would be useful would include:

- Digital clock (to track time)
- Computers (the CPU needs to be triggered by pulses)
- Most digital systems (usually require a central clock that synchronises all parts)



*The CPU and digital clock shown above both rely on continuous pulses. The clock needs a pulse every second where the CPU needs millions (and sometimes even billions), of times a second! Source: Wikipedia*

A circuit which produces a pulse every so often is called an oscillator. Once powered, an oscillator's output will turn on and then turn off. Once this cycle has been completed it repeats itself indefinitely (so long as there is power). But how is an oscillator made? How do you get some components to keep on pulsing? In this kit you will be creating a two transistor oscillator which uses two transistors and a few other components to create an oscillator that generates a few pulses every second so that it flashes (that is why it is called a flasher).

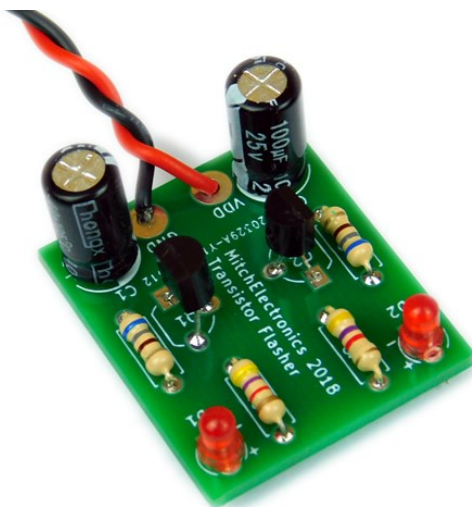

# SCHEMATIC

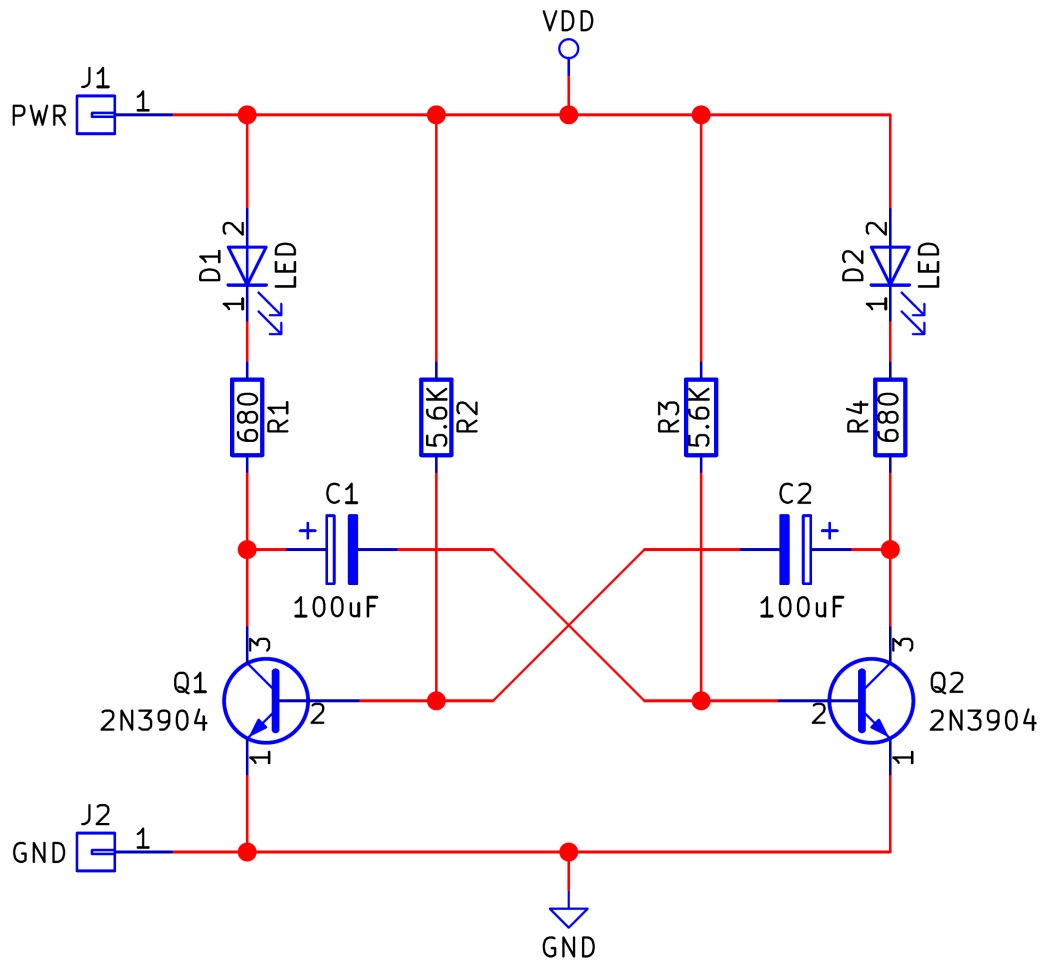

# SCHEMATIC EXPLANATION

---

As this circuit is astable it is difficult to explain unless some initial conditions are stated first. For the initial conditions:

- VCC = 9V
- Q1 has just turned on and Q2 is on
- C1 positive plate was 9V and has just been discharged to 0V through Q1
- C1 negative plate is 0.7V
- C2 positive plate is 9V and C2 negative plate is 0.7V

With Q1 being turned on the positive plate on C1 is suddenly connected to ground (through Q1). Therefore the voltage on the positive plate becomes 0V (and the LED D1 will turn on). Due to capacitive coupling C1 will attempt to keep the voltage across the two plates the same as before (which was  $9V - 0.7V = 8.3V$ ). Therefore the negative plate drops to a voltage of  $-8.3V$ .

The negative plate of C1 is connected in parallel to the base of Q2. Because the base-emitter voltage of a bipolar transistor can never be greater than 0.7V the voltage on the negative plate of C1 can therefore never be greater than 0.7V (but it can be less!). The same applies to C2 and Q1.

When the negative plate of C1 drops to  $-8.3V$  Q2 will turn off hard (this means that it will happen really fast like slamming a door). When Q2 turns off the positive plate of C2 is no longer connected to 0V and therefore quickly charges to 9V (this also results in D2 turning off). In this state Q1 stays on because the negative plate of C2 is 0.7V and Q2 stays off because the negative plate of C1 is less than 0.7V.







This state does not stay around for long. The negative plate of C1 is also connected to 9V through the resistor R3 which means that the voltage on the negative plate begins to rise. Eventually the voltage on the negative plate will rise to 0.7V and the circuit changes into the opposite state.

As the negative plate on C1 is now 0.7V Q2 will turn on. When this happens the positive plate of C2 will be connected to 0V and due to capacitive coupling the negative plate on C2 will drop to  $-8.3V$ . This results in Q1 turning off very quickly and D1 turning off. At the same time the positive plate of C1 will quickly charge to 9V. Again like before this state does not stay around for long! The negative plate of C2 is connected to 9V through R2 and therefore the voltage on the negative plate begins to rise.

Eventually the voltage on the negative plate of C2 will reach 0.7V and because the base of Q1 is connected to the negative plate of C2, Q1 will quickly turn on. This entire cycle keeps repeating indefinitely.

# MATERIALS

Check that you have the following components

Component	Component Name	Quantity	Looks like
2N3904 BJT	Q1, Q2	2	
100uF Capacitor	C1, C2	2	
680Ω Resistor	R1, R4	2	
5.6kΩ Resistor	R2, R3	2	
LED, Green	D1, D2	2	
PP3 Connector	-	1	
PCB	-	1	

## RESISTOR AND CAPACITOR IDENTIFICATION

Colour	1 <sup>ST</sup> Band	2 <sup>ND</sup> Band	3 <sup>RD</sup> Band	Multiplier	Tolerance
BLACK	0	0	0	1Ω	
BROWN	1	1	1	10Ω	±1%
RED	2	2	2	100Ω	±2%
ORANGE	3	3	3	1kΩ	
YELLOW	4	4	4	10kΩ	
GREEN	5	5	5	100kΩ	±0.50%
BLUE	6	6	6	1MΩ	±0.25%
VIOLET	7	7	7	10MΩ	±0.10%
GREY	8	8	8		±0.05%
WHITE	7	7	7		
GOLD					±5%
SILVER					±10%

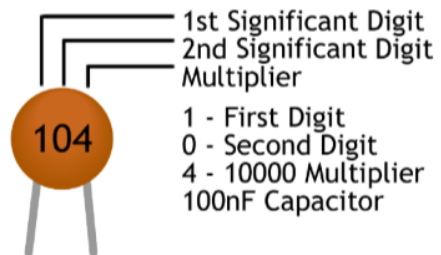

# CONSTRUCTION

---

## Download the electronics construction manual

To learn how to construct circuits on PCBs download the Electronics Construction Manual from MitchElectronics using the link below. This document shows you how to install all electronic components used in MitchElectronics kits. The list below shows the sections relevant to this kit so do not worry if you see component sections in the document that don't come with this kit!

[www.mitchelectronics.co.uk/electronicsConstructionManual.pdf](http://www.mitchelectronics.co.uk/electronicsConstructionManual.pdf)

## Relevant sections in the electronics construction manual

Resistors

Capacitors

LEDs

Transistors

Wires

# IMPORTANT INFORMATION

---



*RoHS Compliant Kit (Lead free)*



*Low Voltage Kit*

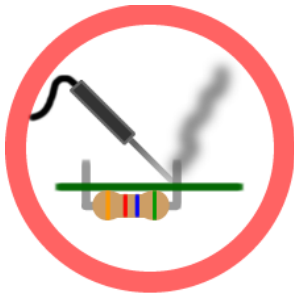

*Caution! Soldering Required*